



HENRY ENGINEERING  
503 Key Vista Drive  
Sierra Madre, CA 91024  
(818) 355-3656

DESCRIPTION:

The UNIVERSAL TURNTABLE CONTROLLER is a remote control unit for use with professional direct-drive turntables. The "UTC" converts the 'single button' start-stop control logic of the turntable to independent Start and Stop outputs, so that separate START and STOP control switches can be used to operate the turntable. The UTC also provides outputs to drive RUN and STOP mode indicator lamps, plus a utility Logic output for interface with auxiliary equipment. When the Universal Turntable Controller is installed, the turntable's own start-stop switch is still useable for cueing records, and the UTC will always stay 'in sync' with the turntable. The UTC is a solid state device employing CMOS circuitry, and uses no relays or optical components. One UTC will control two turntables.

CAUTION:

Installation of the Universal Turntable Controller may require a slight modification of the turntable. This modification, though minor, does require the turntable to be disassembled so that connecting wires can be added. DO NOT attempt to install the UTC unless you are a qualified technician. If you do not fully understand the installation procedure you are not qualified to install the unit!

Disclaimer: Installation and use of the Universal Turntable Controller is solely at the users risk. The UTC may be considered to be a 'modification' of the turntable, and may void any warranty thereof. The user is advised that the turntable manufacturer may refuse to service or repair any turntable that has or has had a UTC connected to it. It is suggested that, should the turntable require service after installing the UTC, the UTC wiring be removed and the turntable restored to its original condition before it is sent in for factory service.

INSTALLATION: (APPLIES TO TECHNICS\*SP-10 AND SP-15 TURNTABLES) \*\*\*SEE SPECIAL NOTE BELOW\*\*\*

Connections to the UTC are made via the two multi-pin headers on the unit; one header is provided for each turntable and control circuitry. The first three pins of each header are connected to the turntable. Pins 4 through 9 connect to the users Start and Stop switches and Run and Stop indicator lamps. The 10th pin is for optional control of auxiliary equipment if desired. Terminate the interface cables with the mating connectors supplied. Use a flat-blade screwdriver to insert the wires into the 'forks' on the connector.

CONNECTION TO TURNTABLE: Note: It is suggested that a schematic diagram of the turntable be obtained to aid in the installation procedure. The UTC is connected to the turntable via a miniature three-circuit plug and jack. (See Figure 1.) Mount the jack on the turntable chassis wherever convenient. Some turntables are already equipped with a two-circuit jack; remove it and install the one supplied in its place. Important: Connect the STATUS wire (from Pin 2) to the TIP, and the CONTROL wire (from Pin 3) to the RING. The TT GROUND wire (from Pin 1) goes to the turntable ground. The CONTROL wire (Pin 3) should be connected in parallel with the turntables internal start-stop switch, which must be a momentary contact closure to ground. Some turntables already provide this connection on a 'factory' remote control jack. The STATUS wire (Pin 2) must be connected to a point in the turntable circuitry that is "HI" (+5 to 35 vdc) when the turntable motor is running, and "LO" (at or near ground) when the motor is stopped. In most cases, the easiest connection point is at the BRAKE SOLENOID. When the motor is stopped, the solenoid is energized hence the junction of the solenoid coil and its switching transistor is near ground. When the motor starts, the transistor turns off and this junction is held HI through the coil. This can be verified by monitoring the voltage at this junction while starting and stopping the turntable motor. Note: There is usually a surge-suppression diode wired across the solenoid coil. Connect the STATUS wire to the solenoid terminal that has the anode of the diode connected to it.

CONNECTION TO CONTROL SWITCHES AND LAMPS: The START and STOP switch outputs of the UTC (Pins 5 & 6) may be connected to momentary switches as shown in Figure 1. Other logic circuitry that switches to ground may also be employed to control the UTC. The RUN and STOP lamp outputs (Pins 7 & 8) may be connected to indicator lamps as shown. These outputs will sink up to 50ma to ground at 24 vdc. LEDs may be used with an appropriate current limiting resistor.

CONNECTION TO AUXILIARY EQUIPMENT: The LOGIC output of the UTC (Pin 10) may optionally be used to control auxiliary equipment if desired. For example, the UTC can switch console audio on and off when the turntable is started and stopped. The Logic output is a maintained HI (+12 vdc) when the turntable is running, and LO when stopped. If opposite logic is required, move R15 to its alternate position, R15A (or R31 to R31A). Refer to the schematic diagram and parts layout. The Logic output is unbuffered; only logic gate inputs should be driven.

OPERATING INSTRUCTIONS:

Push the START switch to start the turntable; push the STOP switch to stop the turntable. The mode indicator lamps will always indicate either the Run or Stop condition. Pushing the turntables own start-stop switch will also switch the mode, and the UTC will switch the logic and indicator lamps accordingly.

\*TECHNICS is a registered trademark of Panasonic Corporation.

\*\*\*FOR TECHNICS SP-10 MKII-A, INSTALL A 330K RESISTOR IN SERIES WITH STATUS LEAD.

INSTALLATION: (APPLIES TO TECHNICS\*SP-25 AND SL-1200 MK2 TURNTABLES)

Connections to the UTC are made via the two multi-pin headers on the unit; one header is provided for each turntable and control circuitry. The first three pins of each header are connected to the turntable. Pins 4 through 9 connect to the users Start and Stop switches and Run and Stop lamps. The 10th pin is for optional control of auxiliary equipment if desired. Terminate the interface cables with the mating connectors supplied. Use a flat-blade screwdriver to insert wires into the 'forks' on the connector.

CONNECTION TO TURNTABLE: Note: It is suggested that a schematic diagram of the turntable be obtained to aid in the installation procedure. In the case of SP-25 and SL-1200 MK2 turntables, it is not necessary to remove the turntable assembly from the base. The turntable control circuitry may be accessed by simply removing the platter from the drive motor shaft and removing the cover that is beneath the platter.

The UTC is connected to the turntable via a miniature three-circuit jack and plug. (See Figure 1.) The jack should be mounted on the turntable chassis. The most convenient place for the jack is on the small metal plate where the turntable AC cord enters the chassis. Carefully drill a  $\frac{1}{4}$ " hole in this plate to mount the jack using the nut supplied.

Wire the miniature three-circuit plug to the UTC header by connecting the TT GROUND lead (from Pin 1) to the sleeve, the STATUS lead (from Pin 2) to the tip, and the CONTROL lead (from Pin 3) to the ring.

Three wires will be connected to the jack; each wire will be connected to a point within the turntable. The sleeve of the jack must be connected to the turntable GROUND, the tip will be connected to the "BRAKE" potentiometer (R 201), and the ring will be connected in parallel with the turntable's START-STOP SWITCH.

Near the front-left corner of the turntable, locate a bundle of wires leading from the Start-Stop and Speed selector switches. Within the bundle, there is a yellow wire. The yellow wire is GROUND. Carefully remove some of its insulation, and tap onto this wire with the lead connected to the mini-jack SLEEVE. (It would be wise to verify that the yellow wire is indeed ground by checking continuity to a known power supply ground point.) Also within the bundle is an orange wire, which is connected to the Start-Stop switch. Verify this by checking continuity between the orange and yellow wires; there should be zero ohms when the Start-Stop switch is pushed. Carefully remove some of the insulation, and tap the orange wire with the lead connected to the RING of the mini-jack.

Now locate the "BRAKE" adjustment potentiometer. It is a small trimpot located on the right side of the PC board. (PC designation R201.) The wire from the TIP of the mini-jack should be connected to the CCW terminal of the pot. This will be the terminal closest to the turntable motor. Important: set the trimpot to its FULL CCW position. Connection of the UTC to the turntable is now complete. The turntable may be reassembled.

CONNECTION TO CONTROL SWITCHES AND LAMPS: Important note: Due to the control logic of SP-25 and SL-1200 MK2 turntables, the Start and Stop switch wiring to the UTC (and Run and Stop lamp wiring) will be reversed from that shown in Figure 1. Connect the START SWITCH to Pin 6. Connect the STOP SWITCH to Pin 5. Connect the RUN LAMP to Pin 8. Connect the STOP LAMP to Pin 7. Connect the SWITCH COMMONS to Pin 4, and the LAMP COMMONS to Pin 9.

CONNECTION TO AUXILIARY EQUIPMENT: See Installation instruction for SP-10 and SP-15 turntables.

OPERATING INSTRUCTIONS:

Push the START switch to start the turntable. Push the STOP switch to stop the turntable. The mode indicator lamps will always indicate either the RUN or STOP condition. Note: When the turntable is started, the RUN lamp will illuminate instantly. However, when the turntable is stopped, the STOP lamp will light after a slight delay, usually .5 second. This is normal, due to the control circuitry of the turntable. Be advised that during this brief delay period, pushing the STOP button again will cause the turntable to restart. This is because the UTC has not yet sensed the "Stop" mode of the turntable (STOP lamp not yet on). If the delay period is objectionable, changing a resistor in the UTC will minimize the delay time. Change R1 (or R17 for TT2) from 100K to 33K to reduce the delay time. Remember that this delay and the minor ambiguity it creates happens only when going from RUN to STOP...never from STOP to RUN. The turntable will always start when the Start switch is closed.

Pushing the turntables own Start-Stop switch will also switch the mode; the UTC will switch the logic and indicator lamps accordingly.

\*TECHNICS is a registered trademark of Panasonic Corporation.

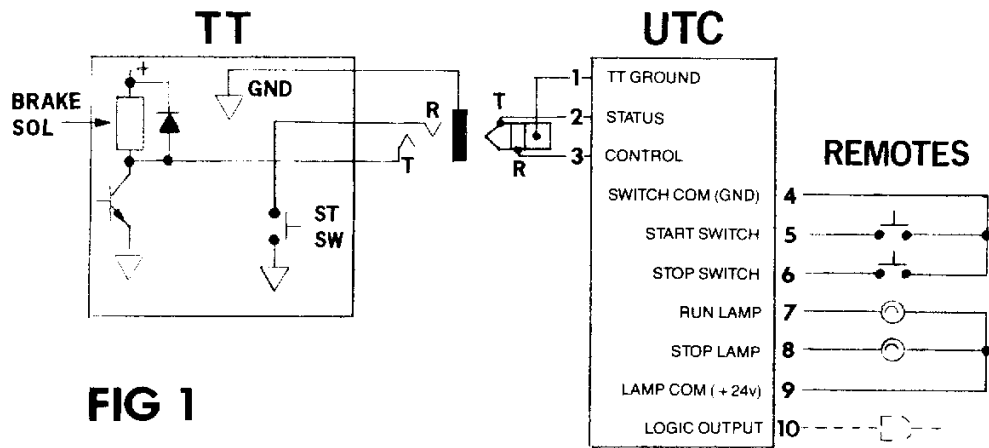

**FIG 1**

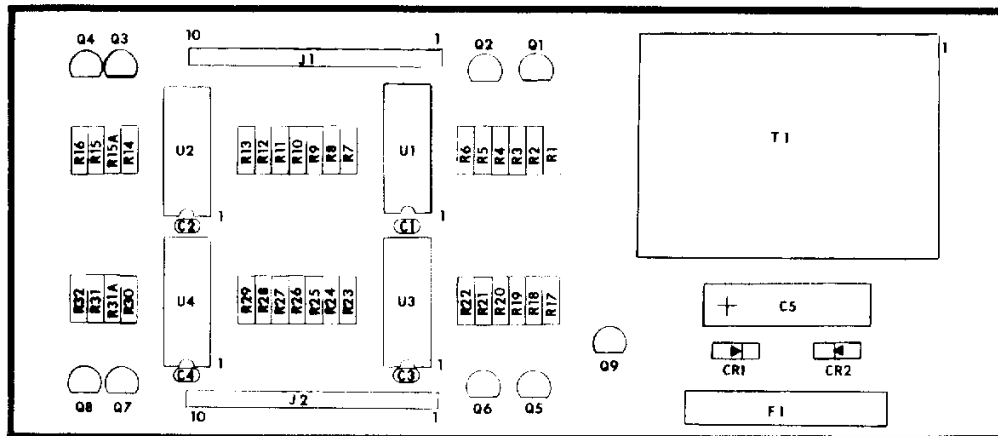
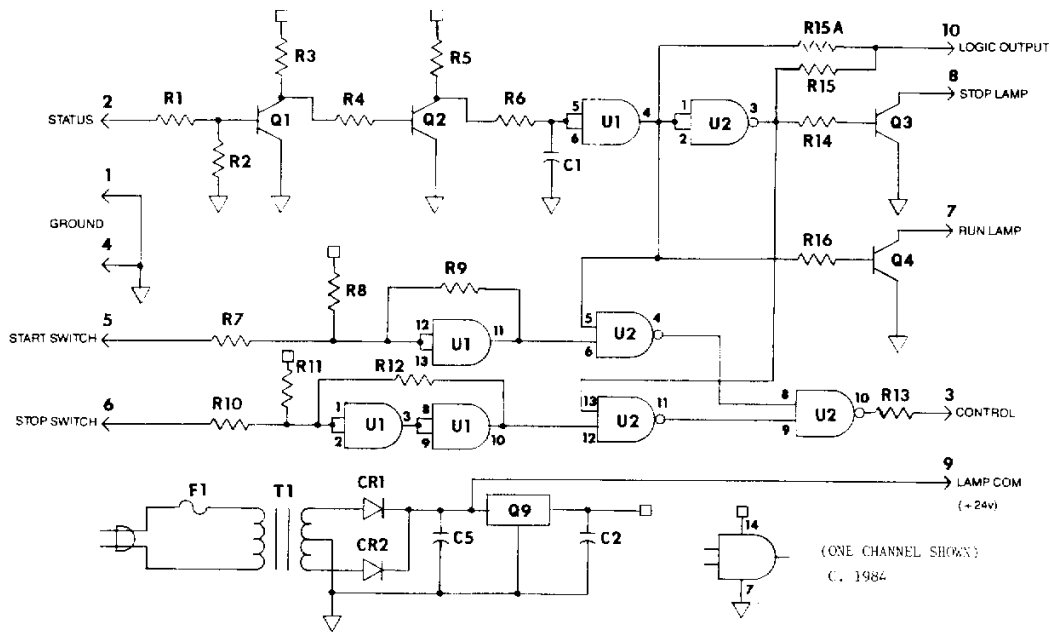

- R1, 2, 17, 18 = 100K
- R7, 10, 13, 15, 23, 26, 29, 31 = 100 OHM
- R9, 12, 25, 28 = OMITTED
- All other R = 10 K
- C1, 2, 3, 4 = .1uf/50
- C5 = 100uf/35
- CR1, 2 = 1N4004
- Q1-Q8 = 2N4401
- Q9 = LM34012
- U1, U3 = CD4071
- U2, U4 = CD4061
- FUSE: 1/8 amp